



WBK41™

Multifunction I/O Module



Compatibility: ✓ WaveBook

Features

- Provides TC inputs, digital I/O and frequency/timer I/O for WaveBook/516E™ systems
- Attaches to the WaveBook/516E or WBK25™ parallel expansion port
- WBK41™ measurements do not consume measurement bandwidth from the WaveBook
- Optional analog output capability
- Optional TC detection
 - ±100 mV input module
 - analog output option (DBK46)



The WBK41™ attaches to the parallel expansion port on the WaveBook/516E™, and provides 14 thermocouple inputs, 40 digital I/O lines, 4 counter inputs, and 2 timer outputs. The WBK41 can also be supplied with an internal, 4-channel, 16-bit, 100-kHz analog output option.

The WBK41 provides thermocouple inputs, counter inputs, timer outputs, digital I/O, and analog output for WaveBook systems

The WBK41 includes a 16-bit, 200-kHz A/D converter, and thus the WBK41 does not consume valuable sampling time from the WaveBook's 1-MHz A/D converter. Measurements with the WBK41 are made synchronous with the WaveBook/516E, providing precise time correlation between readings from both measurement devices.

The built-in TC channels on the WBK41 are accessed via mini-TC connectors on the front panel. The counter/timer functions and 16 bits of digital I/O are accessed via removable front panel screw-terminal connectors. Additional digital I/O and expansion connectors are located at the rear of the WBK41.

The WBK41 can be easily expanded beyond its built-in channel capacity. A maximum WBK41 system can include up to 224 TC input channels, 272 digital I/O channels, 4 analog output channels, 4 counter input channels and 2 timer output channels.

In synchronous master/slave systems or when using a WBK41 module, it is possible to run the slave units at a slower clock rate than that of the master device in the system. This configuration may be necessary when it is desirable to have a systems which has signals that need to be sampled at widely varying rates while remaining time synchronous to the master unit.

WBK41 Multifunction I/O Module Block Diagram

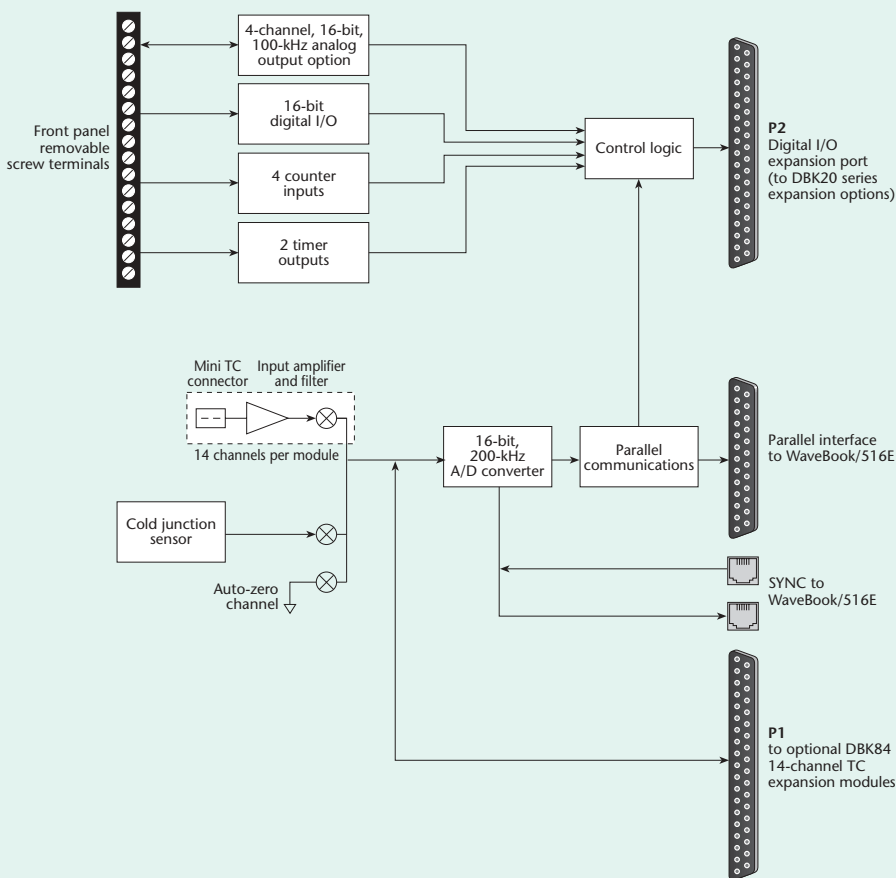



WBK41™

General Information

When such a configuration exists the master unit is connected to the slave or WBK41 via the SYNC ports. The SYNC ports allow the master unit to pass its trigger and acquisition clock signals to the slave devices. When the slave devices receive the clock they can divide the master clock by 1 to 65535 to determine their own acquisition clock rate. Each slave can be programmed to a clock divider independent of other slave units in the system. For example, suppose that a high speed system is configured with 8 accelerometers on the master WaveBook system but we also need to scan 8 much slower moving temperature using a WBK40. In this example, suppose the 8 accelerometer channels are scanned at 100 kHz each while we need to only scan the WBK40 temperature channels at 10 kHz. Here, since we wish to scan the temperature channels 10 times slower than the accelerometer channels, the WBK40 clock divider would be set to 10. This configuration results in the 8 accelerometer channels to be scanned every 10 μ s while the temperature channels on the WBK40 will be scanned every 100 μ s.

Thermocouple Measurements

The 14-channel thermocouple inputs on the WBK41 can accept any type of TC, including types J, K, S, T, E, B, R, and N thermocouples as well as voltage up to ± 100 mV. The WBK41 automatically converts the TC measurement into temperature readings, including cold-junction compensation and linearization. Open TC detection and overload protection up to ± 40 V is also included on every channel. To expand beyond the built-in 14 TC input channels, up to fifteen DBK84 expansion modules can be attached to one WBK41, providing an additional 14 TC input channels per module, or a total of 224 TC channels.

Digital I/O

Forty digital I/O lines are built-into the WBK41. Sixteen of the I/O are accessible via front-panel removable screw terminal connectors, and can be defined under program control as all inputs or all outputs. As inputs, these channels can be scanned synchronously during an acquisition, or asynchronously under program control. As outputs, these lines can be set prior to an acquisition, or changed during an acquisition (if used with a programming environment such as Visual Basic®, C, or LabVIEW®).

In addition to the 16 front-panel digital I/O lines, 24 additional lines are also provided on the rear panel 37-pin D connector. These lines are logically divided into three 8-bit ports, with each port programmable as input or output. As with the front-panel digital I/O, these lines can be scanned as inputs along with other channels in a scan group, or read during an acquisition when a programming environment is being used.

The rear digital I/O port can also be used as a digital I/O expansion port, where it can be expanded up to 256 digital I/O lines using our DBK20™ series of DBK options. These options provide additional signal I/O, including optical isolation and relay closure.

Analog Output (DBK46™)

The optional DBK46™ four channel, 16-bit, 100-kHz analog output card is available for the WBK41™, offering an output range from -10 V to $+10$ V. These outputs are entirely separate from the D/As which are used to determine analog trigger level. On-board the DBK46 is 256 Ksamples of memory, which can store waveforms loaded from the PC. Additional low-speed D/A channels can also be added to the WBK41™ through the use of the DBK2 analog output option card.

When used to generate waveforms, the D/As can be clocked in several different modes. Each D/A can be separately selected to be clocked from one of the sources described below.

Asynchronous internal clock. The on-board programmable clock can generate updates ranging from 1.5 Hz to 100 kHz, independent of any acquisition rate.

Synchronous internal clock. The rate of analog output update can be synchronized to the acquisition rate derived from 100 kHz to once every 5.96 hours.

Asynchronous external clock. A user-supplied external input clock can be used to pace the D/A, entirely independent of analog inputs.

Synchronous external clock. A user-supplied external input clock can pace both the D/A and the analog input.

Frequency Inputs

Four 16-bit counters are built into the WBK41, each capable of counting up to 65,536 TTL-level transitions. Each of the four counters will accept frequency inputs up to 10 MHz. The counters can also be cascaded, allowing over four billion counts to be accumulated. The counter inputs can be read asynchronously under program control, or synchronously as part of an analog scan group. All frequency input lines are accessible via removable front-panel screw-terminal blocks.

Timer Outputs

Two 16-bit TTL-level timer outputs are built into the WBK41, each capable of generating a square wave with a programmable frequency range from 16 Hz to 1 MHz. Timer outputs are accessible via removable front-panel screw-terminal blocks.



WBK41™

Specifications

TC Accuracy at Measurement Temperature in °C (± °C)											
Type	Min	Max	-100	0	100	300	500	700	900	1100	1400
J	-200	760	0.8	0.7	0.7	0.8	0.9	0.9	—	—	—
K	-200	1200	0.9	0.8	0.8	0.9	1.1	1.1	1.2	1.3	—
T	-200	400	0.9	0.8	0.8	0.8	—	—	—	—	—
E	-270	650	0.8	0.7	0.7	0.7	0.8	—	—	—	—
S	-50	1768	—	3.1	2.4	2.0	2.0	1.9	2.0	2.1	2.1
R	-50	1768	—	3.1	2.1	2.0	1.9	1.9	1.7	1.9	2.0
B	50	1780	—	—	—	4.9	3.2	2.8	2.4	2.3	2.0
N28	-270	400	1.2	0.9	0.9	0.9	—	—	—	—	—
N14	0	1300	—	0.9	0.9	0.9	1.1	1.1	1.2	1.3	—

Specifications

General

Supply Voltage Range: 10 to 30 VDC
Power Available for DBK84 Expansion Options:
 Up to eight DBK84 options can be powered from the WBK41; for applications with 9 to 15 options, a DBK32A must be added to the system
Operating Temperature: 0° to +50°C
Storage Temperature: -40° to +80°C
Relative Humidity: 0 to 95%, non-condensing
Vibration: MIL STD 810E
System Connector: DB37 male for P1
TC/mV Connector: Mini-TC connectors
Dimensions: 285 mm W x 220 mm D x 70 mm H (11" x 8.5" x 2.70")
Weight: 1.6 kg (3.5 lbs)

A/D Specifications

Type: Successive approximation
Resolution: 16 bit
Conversion Time: 5 µs
Maximum Sample Rate: 200 kHz
Nonlinearity (Integral): ±1 LSB
Nonlinearity (Differential): No missing codes

Thermocouple Inputs

Functions: TC types J, K, S, T, E, B, R, N; x100 (voltage)
Inputs: 14 differential TC/mV inputs
Input Voltage Range: ±100 mV
Input Impedance: 40M Ohm (differential); 20M Ohm (single-ended)
Input Bandwidth: 4 Hz
Input Bias Current: 10 nA typ
CMRR: 100dB typ
Maximum Working Voltage (signal + common mode): ±10V
Over-Voltage Protection: ±40V
Voltage Accuracy: ±(0.2% of rdg +50 µV)
TC Accuracy*: Valid for one year, 18° to 28°C, see table above
Minimum Resolution: 0.1°C for all TC types

Input Sequencer

Analog, digital and frequency inputs can be scanned synchronously, based on either an internal programmable timer, or an external clock source.
Scan Clock Sources: 2
 1. Internal, programmable from 5 µs to 5.96 hours in 5 µs steps**
 2. External, TTL level input up to 200 kHz max
Depth: 512 locations
Channel-to-Channel Scan Rate: 5 µs
Data Buffer: 64 Ksample FIFO

External Acquisition Scan Clock Input

Maximum Rate: 200 kHz
Clock Signal Range: 0V to +5V
Minimum Pulse Width: 50 ns high, 50 ns low
External SYNC Port: Available on rear panel, allows multiple DaqBook/2000 units to be scan-synchronous (post trigger)

Analog Output (optional DBK46)

The four analog output channels are updated synchronously relative to scanned inputs, and clocked from either an internal onboard clock, or an external clock source. Analog outputs can also be updated asynchronously, independent of any other scanning in the system.
Channels: 4
Resolution: 16 bits
Data Buffer: 256 Ksample
Output Voltage Range: ±10V
Output Current: ±10 mA
Offset Error: ±0.0045V max
Gain Error: ±0.01%
Digital Feedthru: 50 mV when updated
Update Rate: 100 kHz max, 1.5 Hz min (no minimum with external clock)

Settling Time: 10 µsec max to 1 LSB for full-scale step

Clock Sources: 4, programmable
 1. Onboard D/A clock, independent of scanning input clock
 2. SYNC with onboard scanning input clock
 3. External D/A input clock, independent of external scanning input clock
 4. External scanning input clock

Digital I/O

Channels: 40, expandable up to 272 with external digital DBK options
Input Scanning Modes: 2
 1. Asynchronous, under program control at any time relative to input scanning
 2. Synchronous with input scanning
Ports: 3 x 8-bit (rear panel DB37 connector), and 1 x 16-bit (front panel screw terminal); each port is programmable as input or output
Input Protection: ±8KV ESD clamp diodes parallel
I/O Levels: TTL
Sampling/Update Rate: 200 kHz max

Frequency/Pulse Counters

Counter inputs can be scanned synchronously along with analog and digital scanned inputs, based either on internal programmable timer, or an external clock source. Counters can be configured to clear when read, or to totalize and clear under program control.
Channels: 4 x 16-bit; cascadable as 2 x 32-bit
Frequency Measurement Rate: 10 MHz max
Input Signal Range: -15V to +15V
Trigger Level: TTL
Minimum Pulse Width: 50 ns high, 50 ns low

Frequency/Pulse Generators

Channels: 2 x 16-bit
Output Waveform: Square wave
Output Rate: 1 MHz base rate divided by 1 to 65535 (programmable)
High-Level Output Voltage: 2.0V min @ -3.75 mA; 3.0V min @ -2.5 mA
Low-Level Output Voltage: 0.4V max @ 2.5 mA

* Accuracy conditions:
 - Exclusive of thermocouple errors
 - Exclusive of noise
 - VCM=0
 - 25°C ambient temperature, stabilized for 1 hour
 ** Clock does not apply when SYNC'd to a WaveBook



WBK41™

Ordering Information

Ordering Information

Description	Part No.
Multifunction I/O module for the WaveBook/516E and WBK25	WBK41
Internal 4-channel, 16-bit, 100-kHz analog output option	DBK46
14-channel TC expansion module for the WBK41	DBK84
56 channel thermocouple input module	DBK90

Accessories & Cables

Rack mount kit	RackDBK4
Expansion cable for connecting DBK84 options; specify number of DBK84 options (x) to be connected	CA-37-x
SYNC cable for multiunit synchronization; 1 ft.	CA-74-1
5-pin male DIN to 5-pin male DIN provides convenient connection between WBK41 power input connectors and battery packs	CA-115
5-pin DIN to automobile cigarette lighter power cable, 8 ft.	CA-116

Male Connectors for Subminiature TC Jacks

Description	Part No.
Type J male connector	CN-144-JM
Type K male connector	CN-144-KM
Type T male connector	CN-144-TM

For complete information on accessories and cables, visit www.iotech.com/acc

Related Products

WaveBook/516E	p. 17
WBK40	p. 50
DBK20	p. 136
DBK21	p. 136
DBK23	p. 137
DBK24	p. 139
DBK25	p. 141
DBK32A	p. 143
DBK84	p. 170
DBK90	p. 173